

## FEATURES

### Input voltage

115/230Vac  $\pm 15\%$   
( jumper selectable on pcb)

### Input frequency

50/60Hz

### Efficiency

80÷90%

### Switching operating frequency

60KHz typ.

### Input protections

- Inrush current limitation
- EMI filter
- Line fuse

### See table for

- Output voltages and currents
- Line and load regulation
- Output ripple and noise

### Output protections

- Overload protection
- Overvoltage protection

- Short circuit protection

### Hold up time

20msec min.

### Output power

80÷96W (see table)

### Operating temperature

0°C to 50°C

### Temperature power derating

2%/°C (50÷70°C see diag.)

### Storage temperature

-20°C to 85°C

### Temperature drift

0.01%/°C

### Long term stability

Better than 1% after 24 hours

### Cooling

Natural convection

### Dielectric withstand voltage

- Input - Output : 3750Vac (on insulating components)

- Input - P.E.: 1750Vac

### Isolation

- Output - P.E.: 500Vdc

### Comply with

- EN 50081-1
- EN 61000-6-2
- EN 60950
- EN61000-3-2 cl.A
- CE

### Optional features

- C - Closed box
- DC - DC input for AC-DC units
- H - RAIL-DIN mounting
- I - Inhibit input ; inhibits all outputs
- S - Sensing input for load connection compensation
- AL - Alarm relay contact

### Note

- 5V version is provided only with fixed type output connector.

## FEATURES TABLE

MODEL	Output Power W	Vout V	Iout A	Imin A	Imax A	Icc A	Line regulation VIN(min÷max) %	Load regulation (10÷100%) %	Ripple & Noise (0÷20MHz) mV
S112	80	5	16	0	16	20	0.1	$\pm 0.5$	50
S113	96	12	8	0	9	12	0.1	$\pm 0.5$	100
S114	90	15	6	0	7	8	0.1	$\pm 0.5$	100
S116	96	24	4	0	4.5	6	0.1	$\pm 0.5$	100
S117	96	36	3	0	3	4	0.1	$\pm 0.5$	100
S118	96	48	2	0	2	3	0.1	$\pm 0.5$	150
S119	96	96	1	0	1	2	0.1	$\pm 0.5$	200

## S110 VIEW

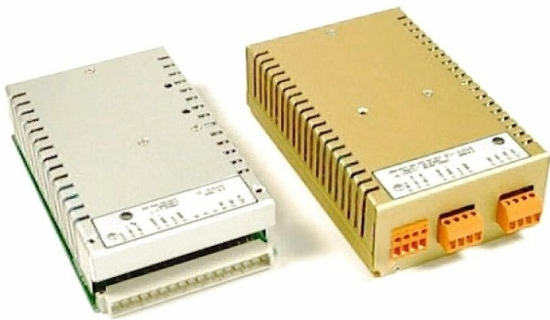

## TEMP. POWER DERATING

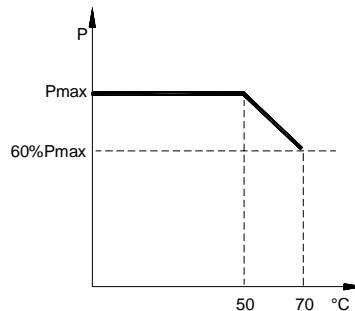

## BLOCK DIAGRAM

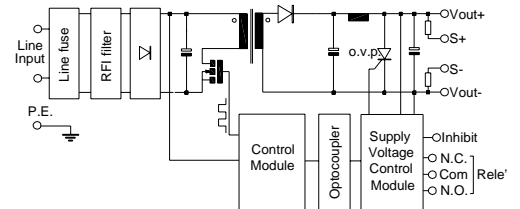

## DIMENSIONS AND CONNECTIONS

enclosure -C- side and top views

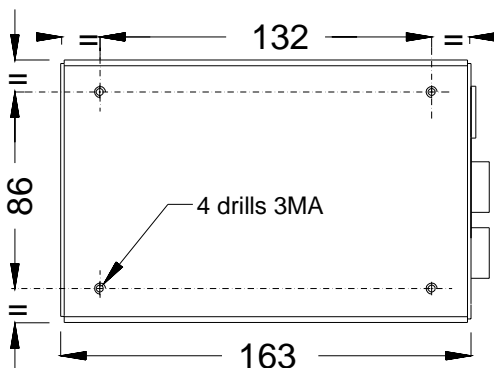

open-frame front and top views

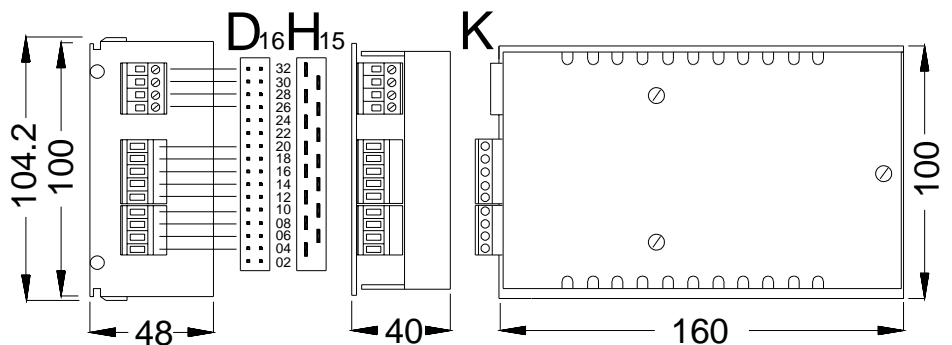

02)Vout+ 04)Vout+ 06)Vout+ 08)Vout- 10)Vout- 12)Rele' N.O. 14)sense- 16)sense+/Rele' N.C.  
18)Inhibit 20)Com Rele' 22)n.c. 24)n.c. 26)ACinputL 28)ACinputN 30)n.c. 32)P.E.

Note: all features are subject to change without notice.